

Standby Compass Calibration

TECHNICAL OVERVIEW

INTRODUCTION:

The Standby Compass Calibrator is designed to permit accurate compensation of permanent magnetization errors and completion of the compass calibration card for an aircraft's standby compass without physically rotating the aircraft. Standby compasses are now compensated by physical rotation of the aircraft, either on the ground or in the air. Use of the Standby Compass Calibrator eliminates the need for conventional airborne or ground swinging processes, allowing the standby compass to be compensated more rapidly and inexpensively.

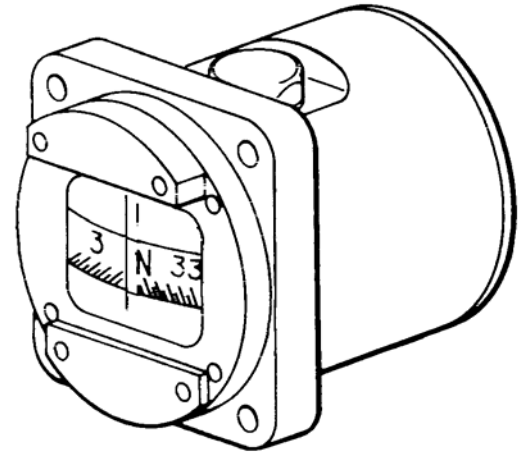

***Eliminates the Physical Rotation of
the Aircraft by Setting a Dial***

Typical Standby Compass

PRINCIPLE OF OPERATION:

The Standby Compass Calibrator performs two separate functions:

1. Cancels the Earth's field at the standby compass.
2. Adds a standard magnetic field which can be rotated to simulate aircraft heading which permits compass error to be determined without physical rotation of the aircraft.

The Earth's field in the vicinity of the standby compass is canceled by a magnet assembly. A wide range of field strengths may be obtained to permit cancellation of the Earth's field at any location on the surface of the Earth by means of an adjustment screw. This adjustment is performed at the actual compass calibration site. The magnet assembly also provides an adjustment to compensate for misalignment of the aircraft with respect to a north-south line.

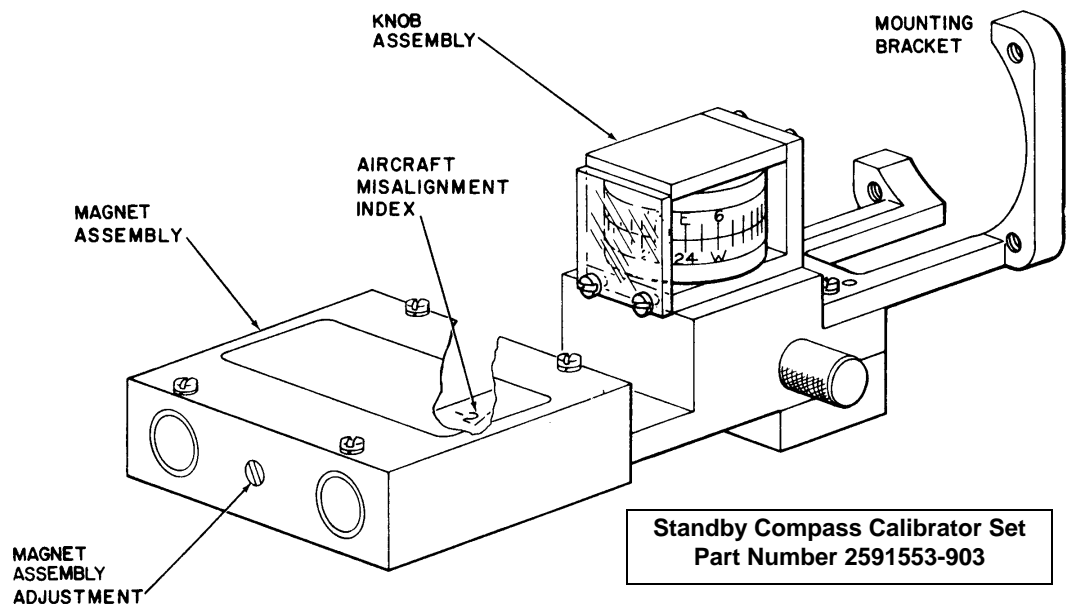

The standby compass calibrator is attached to the aircraft standby compass or by means of a mounting bracket. The simulated magnetic field is produced by magnets in the knob assembly. This simulated magnetic field is rotated in 15 degree increments to produce the desired compass heading. This procedure is performed as required on any aircraft without readjustment of the canceling magnet assembly.

MAGNET ADJUSTMENT PROCEDURE:

The cancellation of the Earth's magnetic field by adjustment of the magnet assembly normalizes the Standby Compass Calibrator for subsequent use for standby compass calibration. The set includes the following:

<u>Description</u>	<u>Firstmark Part Number</u>
Standby Compass Calibrator	2591553-901
Turntable	2969011-1
Tripod	2968806
Master Compass	2593239

Note: Additional mounting bracket required for the B747-400. Additional mounting bracket and Master Compass required for Airbus aircraft.

- (1) A non-magnetic tripod and turntable are set up adjacent to the compass calibration site. The turntable site must be within an approximate 20-foot distance of the position the standby compass will assume when the aircraft is positioned along the north line. This is to ensure that the Earth's magnetic field at the aircraft standby compass and at the turntable site are nearly identical.
- (2) The mounting bracket is removed from the calibrator, and the Master Compass is attached to the bracket.
- (3) The compass and bracket are mounted on the turntable and rotated until the compass indicates a north heading.
- (4) The Standby Compass Calibrator is attached to the mounting bracket with the magnet assembly misalignment adjustment set to 0 degrees.
- (5) The knob assembly is adjusted to the "E" position. The magnet assembly is then adjusted until the compass indicates "E" or 90 degrees.

- (6) The knob assembly is then adjusted to the "W" position, and the magnet assembly is adjusted to remove one half the error between the indicated compass reading and "W" or 270 degrees.

The Standby Compass Calibrator is now normalized to the local magnetic field. The canceling magnet assembly will exactly cancel the Earth's field at the swing location. It should not be necessary to repeat this procedure except for a periodic check, typically every 90 days.

COMPASS CALIBRATION PROCEDURE:

- (1) The aircraft is towed into position on a surveyed north-south line, with the aircraft heading north.
- (2) The angular difference between the aircraft heading and the north-south line is determined and the canceling magnet assembly, which has a range of ± 2 degrees, is adjusted to compensate for the measured angular misalignment.
- (3) The Standby Compass Calibrator is attached to the standby compass as it is mounted in the instrument area by means of 2 of the 4 mounting screws. The Standby Compass Calibrator may be mounted in an upright or inverted position, so that the compass compensation adjustments are accessible.
- (4) The knob assembly is rotated to the four cardinal headings and the standby compass compensation is adjusted in the usual manner.
- (5) The knob assembly is then positioned to each 15-degree increment from 0 through 345 degrees. At each 15-degree increment, the compass reading is noted and the compass calibration card completed.

SPECIFICATIONS:

Accuracy (rms)	± 2.5 degrees
Ambient Field Range	0.06 to 0.42 oersted
Misalignment Adjustment Range	± 2 degrees
Weight	1.6 lb.
Outline Dimensions	9.47 X 3.56 X 3.63 in.

ATTACHMENT TO THE STANDBY COMPASS

The Standby Compass Calibrator is attached to the front of the standby compass. Sufficient space must be available in front of the standby compass for the calibrator. The dimensions of the calibrator are shown below.

Standby Compass Calibrator – Outline drawing

